



P.O. Box 2956 • Syracuse • New York • 13220
 Phone: (315) 433-1150 Fax: (315) 433-1521
 Toll Free US & Canada (800) 334-0837
 Email: sales@infitec.com

DISCONTINUED SERIES DISCONTINUED SERIES DISCONTINUED

CTX SERIES DIGITAL READOUT COUNTDOWN TIMER WITH LCD DISPLAY

FEATURES

- C/MOS Microcontroller Circuitry
- Tactile Pushbutton Timing Adjustments
- Time Delays to 9999 Minutes
- 0.5% Repeat Accuracy
- 1/2 Inch, 4 Digit LCD Display with Colon
- Can Be Used In Direct Sunlight
- Conformally Coated to Withstand Humidity
- UL/cUL Pending

SPECIFICATIONS

1. Time Delay.

- 1.1 Type: C/MOS microcontroller circuitry
- 1.2 Adjustment style: Tactile pushbuttons
- 1.3 Range Maximum

<u>CTX 1</u>	<u>CTX 2</u>
99:59 MIN:SEC/99:59 HRS:MIN	9999 SEC/9999 MIN
9999 SEC/9999 MIN	999.9 SEC/999.9 MIN

- 1.4 Repeat accuracy: \pm 0.5% under fixed conditions
- 1.5 Setting accuracy: \pm 1%
- 1.6 Recycle time: 500 milliseconds
- 1.7 Time delay vs. voltage and temperature: \pm 2%

2. Input.

- 2.1 Operating voltage: 24, 120 & 230 VAC, 12, 24 & 36 VDC
- 2.2 Tolerance: \pm 15% of nominal
- 2.3 Frequency: 50 - 60 Hertz

3. Configuration Jumpers.

<u>CTX 1</u>	<u>CTX 2</u>
Time Format	Time Format
MIN:SEC xx:xx	MIN. xxxx
HRS:MIN xx:xx	SEC. xxxx
SEC. xxxx	MIN. xxx.x
MIN. xxxx	SEC. xxx.x

4. Pushbuttons.

- SW1 = Digit Select
- SW2 = Digit Increment
- SW3 = Start / Stop

5. Output.

- 5.1 Type: Solid state
- 5.2 Form: SPST, normally open
- 5.3 Rating: 200 milliamperes @ 36 VDC / 240 VAC
- 5.4 Visual: 4 - Digit liquid crystal display with colon

6. Protection.

- 6.1 Transient: (10/1000 uSec pulse): 11 Joules
- 6.2 Polarity: DC units are reverse polarity protected

7. Mechanical.

- 7.1 Mounting: #6 screw clearance (4 places)
- 7.2 Termination: (1) 4 conductor, .100 pitch pin header connector
- 7.3 Style: Open board / panel mount (see recommended cutout dimensions)

8. Environmental.

- 8.1 Operating temperature: -20°C to +70°C
 - 8.2 Storage temperature: -25°C to +80°C
- Note: OK for use in direct sunlight.

MODE OF OPERATION - COUNTDOWN TIMER

Setting Time Delay

1. Select the digit to be changed by repeatedly pressing the "Digit Select" button.
2. Increment the selected digit by repeatedly pressing the "Digit Increment" button.
3. Pressing the "Start/Stop" button will store the new time and exit the "Time Setting" mode.

Note: When the pushbuttons have been inactive for greater than 30 seconds, the display will revert back to the last saved time.



Control Operation

Initial application of input power to the control restores the last set time setting and the output is de-energized.

Power must be applied to the control at all times, prior to and during timing.

Momentary pressing of the "Start/Stop" button will cause the load to energize and the countdown timer to start timing.

- If no further action is taken, the countdown timer will count down to zero, the load will de-energize and the time delay setting will revert back to the last time set.
- If the "Start/Stop" button is pressed for less than five seconds, while the load is energized, the load will de-energize and the timing will be suspended until the "Start/Stop" button is pressed again. There is no limit to the number of times this action can occur in a given cycle.
- If the "Start/Stop" button is pressed for greater than five seconds, while the load is energized, the load will de-energize and the time delay setting will revert back to the last time set.

Cycle Counter and Hour Meter

Each time a new timing cycle is initiated, the "Cycle Count" and the total time the load is energized (in minutes or hours [see format configuration]) are accumulated in non-volatile memory.

To Display Count

Press and hold the "Digit Select" button for greater than ten seconds while NOT in timing cycle will cause the display to show the current "Cycle Count" and the left most decimal point in the display will flash.

To Display Hour-Count

While in the "Cycle Count" display mode, press the "Digit Increment" button and the display will toggle to the "Hour Count" indicating the total accumulated time the load has been energized since installed ("Hour Meter" mode). The right most decimal point will flash. Pressing of the "Digit Increment" button will cause the display to toggle between "Cycle Count" and "Hour Meter" mode.

To End Cycle / Hour Count Display Mode

Pressing the "Start/Stop" button at any time will also cause the display to revert back to the last set time and ready the control for a new timing cycle. When the pushbuttons have been inactive for greater than 30 seconds, the display will automatically revert back to the last set time and the control will be ready for a new timing cycle.

Note: Shorting reset pads labeled "R" on the P.C. Board during power-up will reset the "Cycle Count" and "Hour Meter" to "0".

Removal and re-application of input power will reset time control.

DISCONTINUED

DIMENSIONS

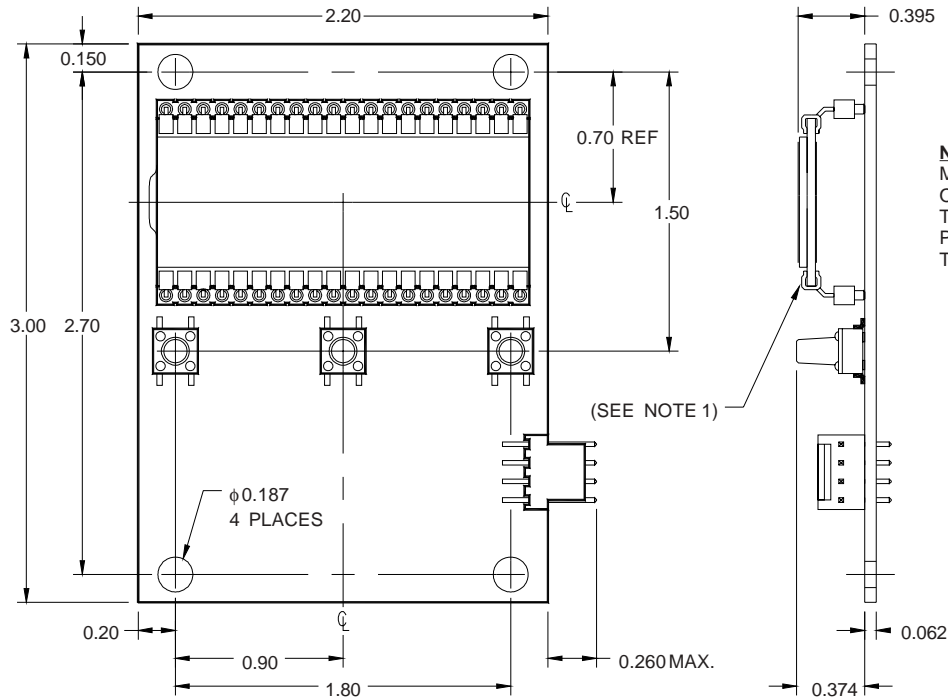

NOTE 1: IF THIS CONTROL IS MOUNTED TO A METAL PANEL (OR OTHER ELECTRICALLY CONDUCTIVE MATERIAL) THE DISPLAY PINS MUST BE INSULATED FROM THE PANEL.

CONNECTION DIAGRAMS

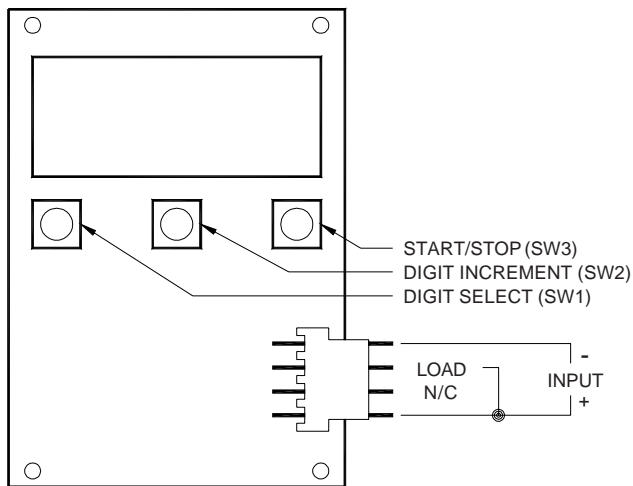

RECOMMENDED PANEL LAYOUT

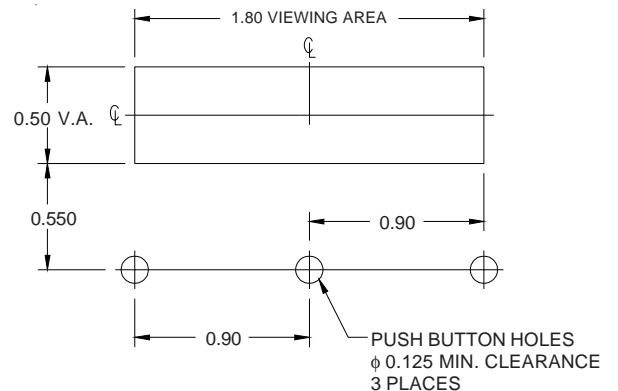

ORDERING INFORMATION

SERIES	INPUT VOLTAGE	TIME RANGE FORMAT
CTX	1 - 12 VDC 2 - 24 VDC 4 - 24 VAC 5 - 120 VAC 6 - 230 VAC 9 - 36 VDC	1 - 99:59 MIN:SEC / 99:59 HRS:MIN 9999 SEC. / 9999 MIN. 2 - 9999 SEC. / 9999 MIN. 999.9 SEC / 999.9 MIN.