



P.O. Box 2956 • Syracuse • New York • 13220
 Phone: (315) 433-1150 Fax: (315) 433-1521
 Toll Free US & Canada (800) 334-0837
 Email: sales@infitec.com

S SERIES OPEN BOARD TIME DELAY RELAYS

FEATURES

- C/MOS Digital Circuitry
- Time Delays To 1000 Minutes
- No First Cycle Effect
- 0.5% Repeat Accuracy
- 2% Stability Over Voltage And Temperature
- Wide Voltage Selection 24-230 VAC, 12 - 110 VDC
- Low Cost, Open Board Construction
- DPDT 10 Ampere Output Rating
- UL / cUL Recognized

SPECIFICATIONS

1. Time Delay.

- 1.1 Type: C/MOS Digital Circuitry
- 1.2 Range: From 0.05 seconds to 1000 minutes. Fixed delays available (see *time delay range chart*)
- 1.3 Repeat accuracy: $\pm 0.5\%$ under fixed conditions
- 1.4 Setting accuracy: $\pm 10\%$
- 1.5 Reset time: 100 milliseconds maximum
- 1.6 Recycle time: 150 milliseconds
- 1.7 Time delay vs. voltage and temperature: $\pm 2\%$

2. Input.

- 2.1 Operating voltage: 24, 120 & 230 VAC, 12, 24 & 110 VDC
- 2.2 Tolerance: $\pm 20\%$ of nominal
- 2.3 Frequency: 50 - 60 Hertz

3. Output.

- 3.1 Type: Electromechanical relay
- 3.2 Form: DPDT
- 3.3 Rating: 10 amperes resistive at 120 VAC
- 3.4 Life: Electrical - full load - 1,000,000 operations
 Mechanical - 10,000,000 operations

4. Protection.

- 4.1 Transient: ± 1500 volts for 150 microseconds
- 4.2 Polarity: DC units are reverse polarity protected
- 4.3 Dielectric breakdown: 1500 volts RMS minimum

5. Mechanical.

- 5.1 Mounting: #6 screw clearance (4 places)
- 5.2 Termination: 3/16" or 1/4" quick connect terminals
- 5.3 Style: Open board / surface mount

6. Environmental.

- 6.1 Operating temperature: -20°C to $+80^{\circ}\text{C}$
- 6.2 Storage temperature: -30°C to $+85^{\circ}\text{C}$
- 6.3 Humidity: 95% relative, non-condensing

MODE OF OPERATION - SERIES

DELAY ON MAKE - SMR

Upon application of power to the input terminals, the time delay begins. At the completion of the pre-selected time delay, the output contacts transfer. Reset is accomplished by removal of input power. There is no false output when reset during timing.

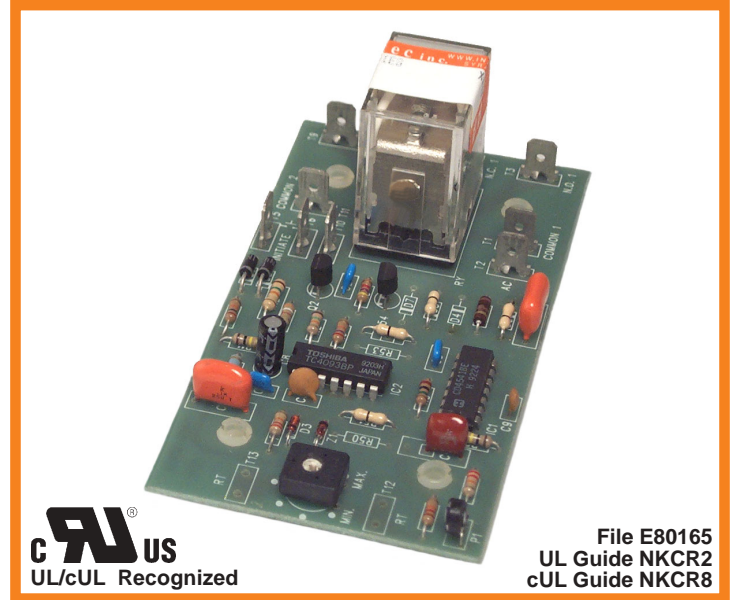
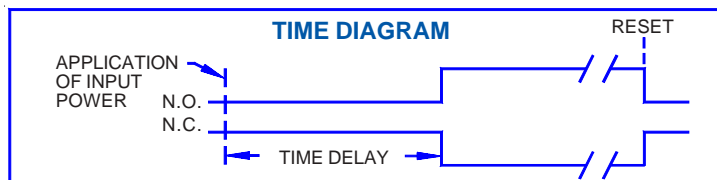

INTERVAL - SIR

Upon application of power to the input terminals, the output contacts immediately transfer and the time delay begins. At the completion of the pre-selected time delay, the output contacts revert to their original position. Reset is accomplished by removal of input power.

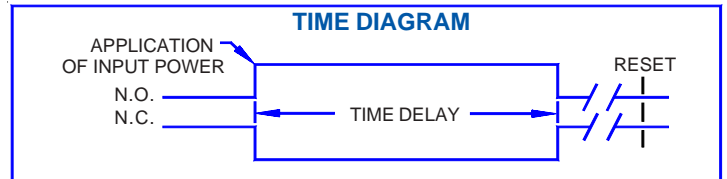

SINGLE SHOT - SSR

Power must be applied to the input at all times prior to and during timing. Upon closure of the initiate switch (momentary or maintained) the output contacts transfer and the time delay begins. At the completion of the pre-selected delay period, the output contacts revert to their original position. Removal of input power will reset the control.

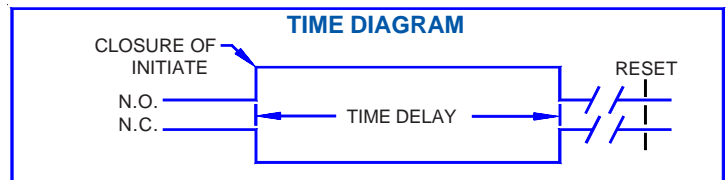

DELAY ON BREAK - SBR/STR *

Power must be applied to the input at all times prior to and during timing. Upon closure of the initiate switch, the output contacts transfer and remain transferred if no further action is taken. When the initiate switch is opened, the time delay begins. At the completion of the pre-selected delay period the output contacts revert to their original position. Closure of initiate during timing will reset the delay period. Removal of input power will reset the control.

*STR is the same except it is trailing edge triggered. Load energizes when initiate switch is opened.

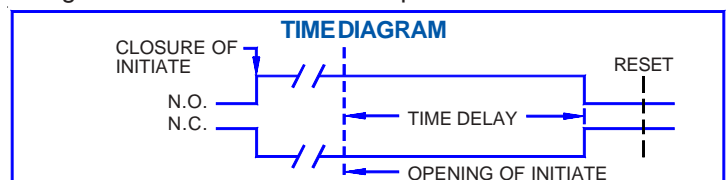

RETRIGGERABLE ONE-SHOT - SOR

Power must be applied to the input at all times prior to and during timing. Upon closure of the initiate switch (momentary or maintained) the output contacts transfer and the time delay begins. At the completion of the pre-selected delay period, the output contacts revert to their original position. **NOTE:** Momentary or maintained closure of initiate switch during timing will reset the time delay.

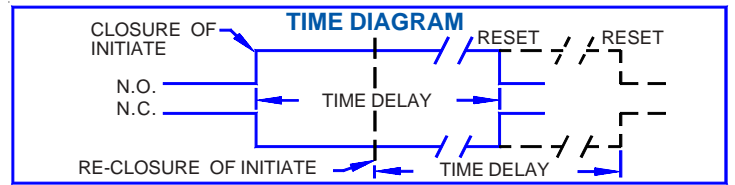

DIMENSIONS

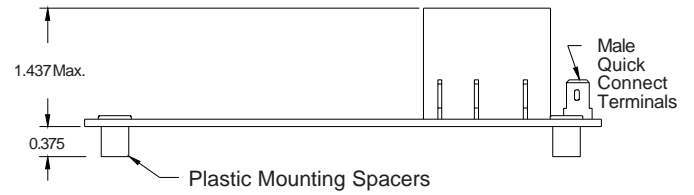
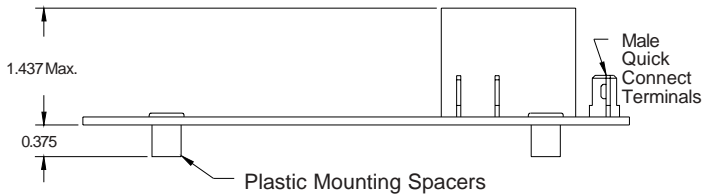
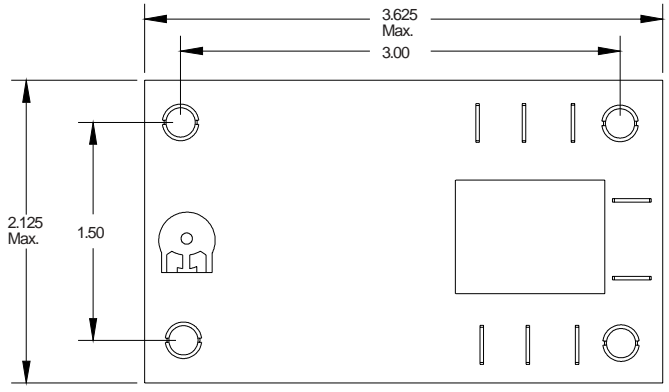
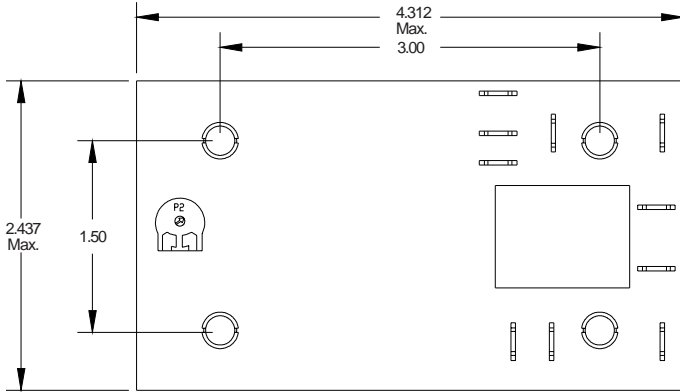

SBR, SOR, SSR, STR

SIR, SMR

CONNECTION DIAGRAM

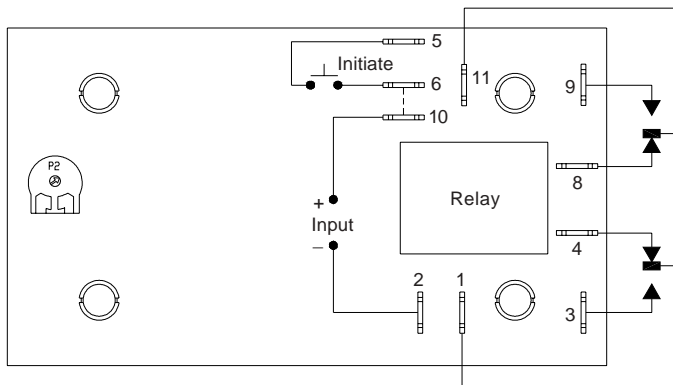

SBR, SOR, SSR, STR

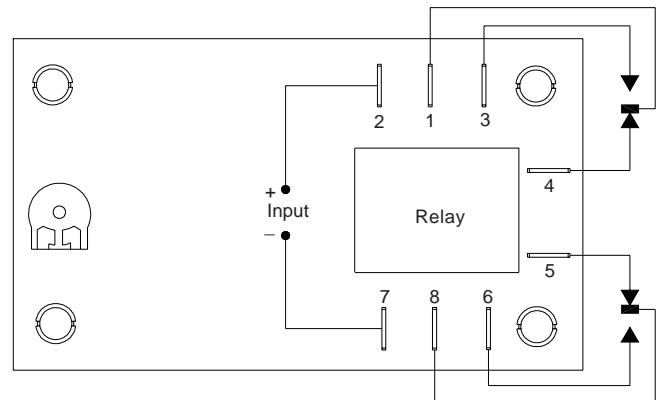

SIR, SMR

ORDERING INFORMATION

| SERIES | TERMINATION | INPUT VOLTAGE | ADJUSTMENT | TIME DELAY RANGE |
|--------|-------------------------|---------------|-----------------------|----------------------------|
| SBR | 2 - 3/16" Quick Connect | 1 - 12 VDC | 0 - Local Adjust | See Time Delay Range Chart |
| SIR | | 2 - 24/28 VDC | | |
| SMR | 3 - 1/4" Quick Connect | 3 - 110 VDC | 1 - Fixed | |
| SOR | | 4 - 24 VAC | 2 - Remote Adjustment | |
| SSR | | 5 - 120 VAC | | |
| STR | | 6 - 230 VAC | | |