



P.O. Box 2956 · Syracuse · New York · 13220
 Phone: (315) 433-1150 Fax: (315) 433-1521
 Toll Free US & Canada (800) 334-0837
 Email: sales@infitec.com

UIS100A / UMS100A / UMS200 ENCAPSULATED, UNIVERSAL DIGITAL TIMING CONTROL



UL/cUL Recognized

File E80165
 UL Guide NKCR2
 cUL Guide NKCR8

FEATURES

- C/MOS Digital Timing
- 80° Ambient Operation
- Knob or Remote Adjustable From .2 To 8 Minutes
- Encapsulated Construction
- 2 Terminal Series Connection (UMS100A & UMS200)
- High Reliability
- No First Cycle Effect
- Low Cost
- 19-264 Volts AC or DC Operation
- 1 Unit To Stock
- UL/cUL Recognized

SPECIFICATIONS

- 1. Time Delay.**
 - 1.1 Type: Knob adjustable (UMS200 = Remote adj.)
 - 1.2 Range: 0.2 to 8 minutes
 - 1.3 Repeat accuracy: $\pm 0.5\%$ under fixed conditions
 - 1.4 Reset time: 50 milliseconds
 - 1.5 Recycle time: 100 milliseconds maximum
- 2. Input.**
 - 2.1 Operating voltage: 19 to 264 volts AC or DC in two ranges
 - 2.2 Frequency: 50 - 60 Hertz
- 3. Output.**
 - 3.1 Type: Solid state
 - 3.2 Form: SPST
 - 3.3 Rating: 1 ampere maximum (40mA minimum or consult factory) 10 ampere inrush
 - 3.4 Life: 100,000,000 operations minimum
- 4. Protection.**
 - 4.1 Transient: ± 1500 volts for 150 microseconds
 - 4.2 Dielectric breakdown: 1500 volts RMS minimum
- 5. Mechanical.**
 - 5.1 Mounting: One #8 or #10 screw
 - 5.2 Termination: 1/4" quick connect terminals
 - 5.3 Style: Surface mount encapsulated
- 6. Environmental.**
 - 6.1 Operating temperature: -20°C to +80°C
 - 6.2 Storage temperature: -30°C to +85°C
 - 6.3 Humidity: 95% relative non-condensing

MODE OF OPERATION - SERIES Delay On Make - UMS100A & UMS200

Upon application of power to the input terminals, the time delay begins. At the completion of the pre-selected time delay, the output contact transfers. Reset is accomplished by removal of input power. There is no false output when reset during timing.

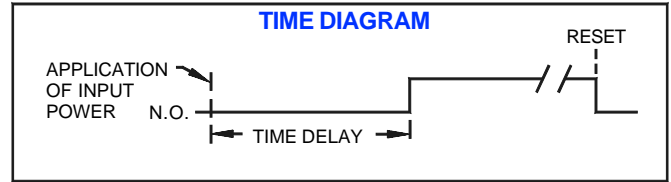

Interval - UIS100A

Upon application of power to the input terminals, the output contact immediately transfers and the time delay begins. At the completion of the pre-selected time delay, the output contact reverts to its original position. Reset is accomplished by removal of input power.

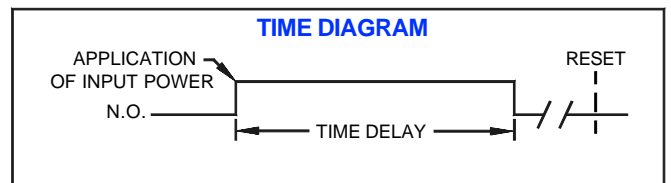

DIMENSIONS

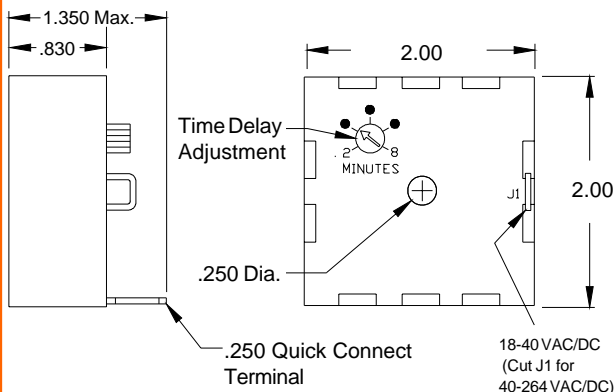

CONNECTION DIAGRAMS & ORDERING INFORMATION

