

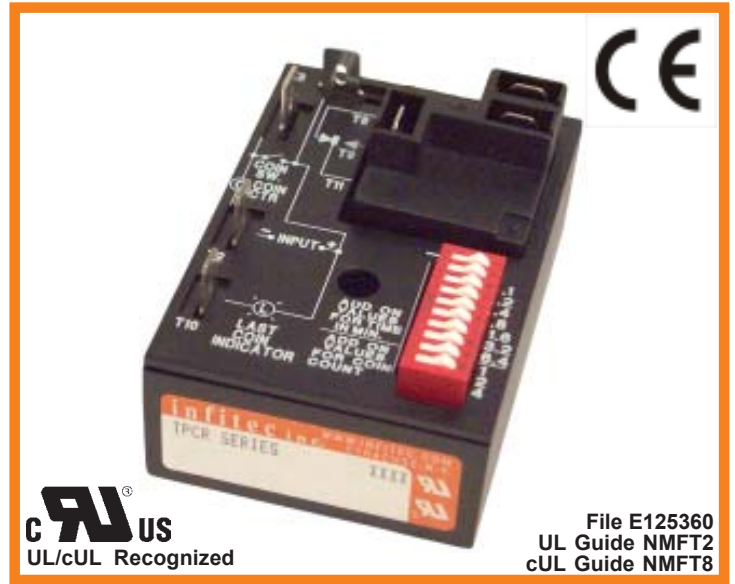

TPCR SERIES COIN VENDING TIMER

P.O. Box 2956 · Syracuse · New York · 13220
 Phone: (315) 433-1150 Fax: (315) 433-1521
 Toll Free US & Canada (800) 334-0837
 Email: sales@infitec.com



FEATURES

- Microcontroller Circuitry
- Accumulates 1 to 255 Coins
- Multiple Time Delay Selection
- Encapsulated To Withstand Harshest Environment
- 0.5% Repeat Accuracy
- Contacts Rated Up To 30 amps 2hp @ 240VAC
- UL / cUL Recognized
- CE Marking

SPECIFICATIONS

1. Time Delay.

- 1.1 Type: Microcontroller circuitry
- 1.2 Range: Adjustable 1 second to 254 minutes in 5 ranges (see ordering information)
- 1.3 Adjustment: 7 positions of 10 position DIP switch (see adjustment information)
- 1.4 Repeat accuracy: ± 0.5% under fixed conditions
- 1.5 Setting accuracy: ± 1%
- 1.6 Reset time: 250 milliseconds maximum
- 1.7 Recycle time: 100 msec. during timing
250 msec. after timing
- 1.8 Time delay vs. voltage and temperature: ± 2%

2. Input.

- 2.1 Operating voltage: 24, 120 & 230 VAC,
12, 24/28 VDC (see ordering information)
- 2.2 Tolerance: ± 20% of nominal
- 2.3 Frequency: 50 - 60 Hertz

3. Output.

- 3.1 Type: Electromechanical relay
- 3.2 Form: SPST or SPDT (see ordering information)
- 3.3 Rating: See Output Rating Chart
Note: Available with isolated or non-isolated contacts.
- 3.4 Life: Electrical - full load - 100,000 operations
Mechanical - 10,000,000 operations

OUTPUT CONTACT RATING CHART			
	30 VDC	125 VAC	240 VAC
HIGH POWER			
N.O.	20A	20A, 1hp	20A, 2hp
N.C.	10A	10A, 1/4hp	10A, 1/2hp
HEAVY DUTY			
N.O.	30A	30A, 1hp	30A, 2hp

4. Last Coin Indicator Output ('L' mode only)

- 4.1 Type: Solid state
- 4.2 Form: SPST, N.O.
- 4.3 Rating: AC: 500 mA RMS, half-wave
DC: 500 mA DC

5. Coin Count Functions.

- 5.1 Switch Type: mechanical or electronic (counts on closure) consult factory for proper connections to electronic switches
- 5.2 Minimum Switch Closure Time: 25 milliseconds
- 5.3 Minimum Switch Open Time (between closures): 20 milliseconds minimum
- 5.4 Count Range: 1 to 7 switch closures
- 5.5 Count Adjustment: 3 positions of 10 position DIP switch (see adjustment information)

6. Protection.

- 6.1 Electrical fast transient Immunity: IEC 61000-4-4
- 6.2 Surge Immunity: IEC61000-4-5
- 6.3 Dips, shorts and interruptions Immunity: IEC61000-4-11
- 6.4 DC units are reverse polarity protected
- 6.5 Dielectric breakdown: 1500 volts RMS minimum

7. Mechanical.

- 7.1 Mounting: One #8 or #10 screw
- 7.2 Termination: 1/4" quick connect terminals
- 7.3 Style: Surface mount / encapsulated

8. Environmental.

- 8.1 Operating temperature: -20°C to +80°C
- 8.2 Storage temperature: -30°C to +85°C
- 8.3 Humidity: 95% relative, non-condensing

MODE OF OPERATION

STANDARD COIN TOTALIZER & VENDING TIMER

Power is applied to the unit at all times prior to and during timing. Coin switch closures are counted until their total equals the dip switch setting. At this point the output contact transfers and the time delay begins. Upon completion of the pre-selected time delay the output contact reverts to its original position and the control resets. Removal and re-application of input power will reset the control.

ACCUMULATING VENDING TIMER

Power is applied to the unit at all times prior to and during timing. Coin switch closures are counted until their total equals the dip switch setting. At this point the output contact transfers and the time delay begins. For every coin switch closure counted, prior to or during timing, the unit adds the time set to the total vending time. Upon completion of the time delay, the output contact reverts to its original position and the controls resets. Removal and re-application of input power will reset the control.

ACCUMULATING VENDING TIMER/LAST COIN INDICATOR

Same as ACCUMULATING VENDING TIMER except when the remaining time is less than the set time, the last coin indicator is activated. If additional coins are added the last coin indicator is deactivated until the remaining time is again less than the set time.

DIMENSIONS

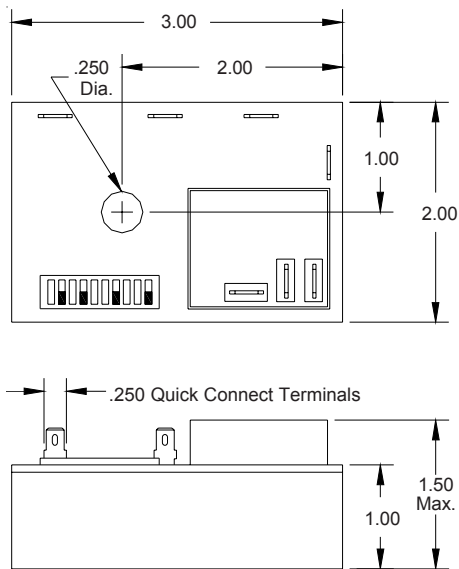

ADJUSTMENT INFORMATION

	TIME RANGE 1	TIME RANGE 2	TIME RANGE 3	TIME RANGE 4
	1	5	0.1	.25
	2	10	0.2	.5
	4	20	0.4	1
	8	40	0.8	2
	16	80	1.6	4
	32	160	3.2	8
	64	320	6.4	16
	1	1	1	1
	2	2	2	2
	4	4	4	4

ADD 'ON' VALUES AS INDICATED FOR TIME IN SECONDS (or minutes)

ADD 'ON' VALUES FOR COIN COUNT

MODE 'S' COIN TOTALIZER

(Example Setting)
Time Range: 2
Time Delay: 60 secs.
2 coins to start
Total Time: 60 secs.

MODE 'A' & 'L' ACCUMULATING TIMER

(Example Setting)
Time Range: 2
Time Delay: 60 secs. per coin
2 coins to start
Total Time: 120 secs.

CONNECTION DIAGRAMS

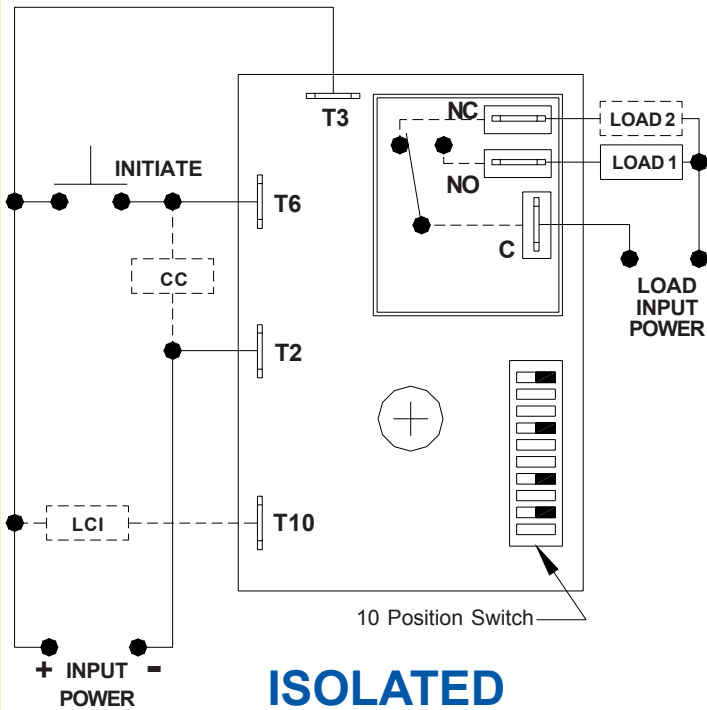

ISOLATED

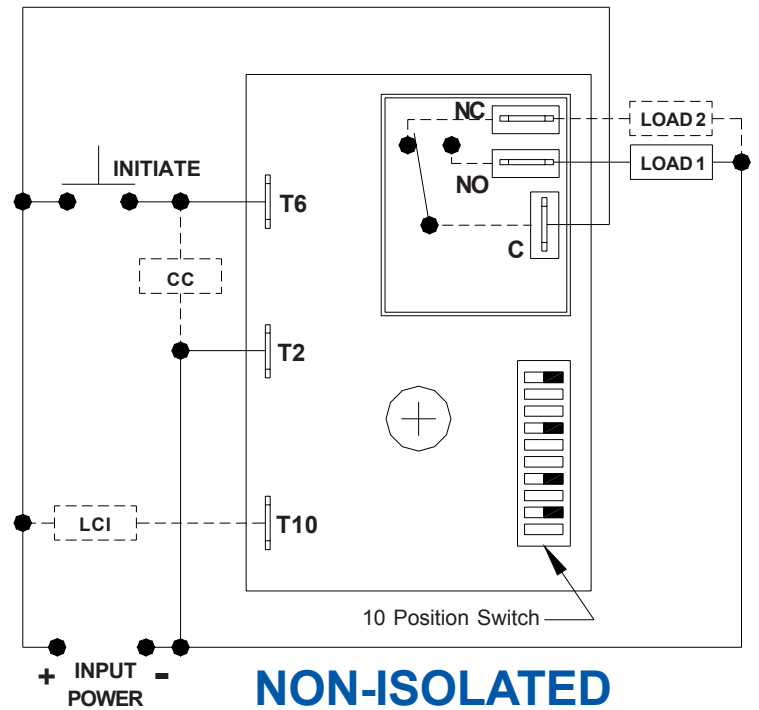

NON-ISOLATED

OPTIONAL OUTPUTS / LOADS

LOAD 2 = AUXILIARY LOAD (OFF DURING TIMING)

CC = COIN COUNTER

LCI = LAST COIN INDICATOR - 'L' MODE ONLY - MUST BE SAME VOLTAGE AS INPUT VOLTAGE

ORDERING INFORMATION

SERIES	INPUT VOLTAGE	RATING	TIME RANGE	MODE
TPCR	1 - 12 VDC	B - High Power, SPDT, (isolated)	1 - 1 - 127 sec.	S - Standard Coin Totalizer/Timer
	2 - 24/28 VDC	C - Heavy Duty, SPST, (isolated)	2 - 5 - 635 sec.	
	4 - 24 VAC	F - High Power, SPDT, (non-isolated)	3 - 0.1 - 12.7 min.	
	5 - 120 VAC	G - Heavy Duty, SPST, (non-isolated)	4 - .25 - 31.75 min.	
	6 - 230 VAC		5 - 2 - 254 min.	
				A - Accumulating Timer
				L - Accumulating Timer w/last coin indicator output