



DUR SERIES UNIVERSAL PLUG-IN TIME DELAY RELAY

P.O. Box 2956 · Syracuse · New York · 13220
 Phone: (315) 433-1150 Fax: (315) 433-1521
 Toll Free US & Canada (800) 334-0837
 Email: sales@infitec.com

FEATURES

- Microcontroller Circuitry
- Switch Selectable Delays To 17.7 Days in 8 Ranges
- Eight Different Modes Of Operation
- 1% Setting Accuracy
- 0.1% Repeat Accuracy
- Wide Voltage Selection 24-230 VAC, 12 - 24/28 VDC
- 10 Ampere SPDT & DPDT Output Rating
- LED For Power And Output Indication
- CE Marking
- UL / cUL Recognized

SPECIFICATIONS

1. Time Delay.

- 1.1 Type: Microcontroller circuitry
- 1.2 Range: Switch selectable from 0.1 secs. to 17.7 days in 8 ranges
- 1.3 Adjustment: Three switches are provided to set seconds/minutes and multipliers of x0.1, x1, x10 or x100 secs./mins.
- 1.4 Repeat accuracy: $\pm 0.1\%$ under fixed conditions
- 1.5 Setting accuracy: $\pm 1\%$
- 1.6 Reset time: 100 ms minimum
- 1.7 Recycle time: 50 ms during and 100 ms after timing
- 1.8 Initiate time: 75 ms maximum
- 1.9 Time delay vs. voltage and temperature: $\pm 2\%$

2. Input.

- 2.1 Operating voltage: 24, 120 & 230 VAC, 12, 24/28 & 110 VDC
- 2.2 Tolerance: $\pm 20\%$ of nominal
- 2.3 Frequency: 50 - 60 Hertz

3. Output.

- 3.1 Type: Electromechanical relay
- 3.2 Form: DPDT or SPDT (see base style connections)
- 3.3 Rating: 10 amperes resistive @ 30 VDC, 120/240 VAC
- 3.4 Life: Electrical - full load - 100,000 operations
 Mechanical - 10,000,000 operations

4. Protection.

- 4.1 Electrical fast transient Immunity: IEC 61000-4-4
- 4.2 Surge Immunity: IEC 61000-4-5
- 4.3 Dips, shorts and interruptions Immunity: IEC 61000-4-11
- 4.4 Polarity: D.C. units are reverse polarity protected
- 4.5 Dielectric breakdown: 1500 volts RMS minimum

5. Mechanical.

- 5.1 Mounting: Plug-in
- 5.2 Termination: octal (8 pin), Magnal (11 pin) or 11 pin stab/square base plug-in

6. Environmental.

- 6.1 Operating temperature: -20°C to $+80^{\circ}\text{C}$
- 6.2 Storage temperature: -30°C to $+85^{\circ}\text{C}$
- 6.3 Humidity: 95% relative, non-condensing

MODE OF OPERATION DELAY ON MAKE

Upon application of power to the input terminals, the time delay begins. At the completion of the pre-selected time delay, the output contacts transfer. Reset is accomplished by removal of input power. There is no false output when reset during timing.

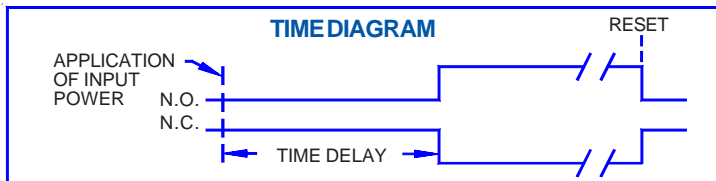

INTERVAL

Upon application of power to the input terminals, the output contacts immediately transfer and the time delay begins. At the completion of the pre-selected time delay, the output contacts revert to their original position. Reset is accomplished by removal of input power.

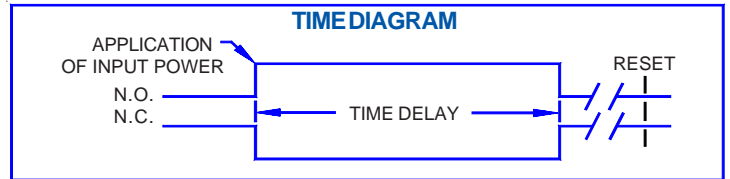

SINGLE SHOT

Power must be applied to the input at all times prior to and during timing. Upon closure of the initiate switch (momentary or maintained) the output contacts transfer and the time delay begins. At the completion of the pre-selected delay period, the output contacts revert to their original position. Removal of input power will reset the control.

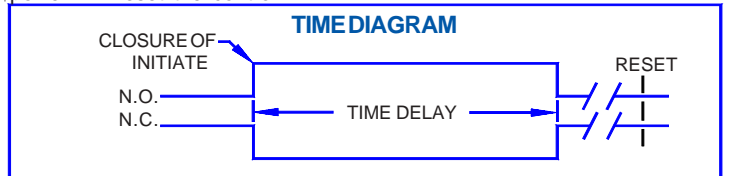

DELAY ON BREAK

Power must be applied to the input at all times prior to and during timing. Upon closure of the initiate switch, the output contacts transfer and remains transferred if no further action is taken. When the initiate switch is opened, the time delay begins. At the completion of the pre-selected delay period the output contacts revert to their original position. Closure of initiate during timing will reset the delay period. Removal of input power will reset the control.

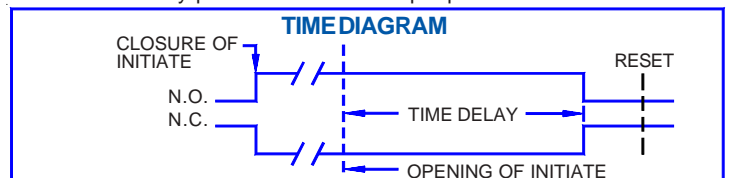

TOGGLE/SINGLE SHOT

Power must be applied to the input at all times prior to and during timing. Upon closure of the initiate switch (momentary or maintained) the output contacts transfer and the time delay begins. Upon re-closure of the initiate switch or at the completion of the pre-selected time delay period, the output contacts revert to their original position.

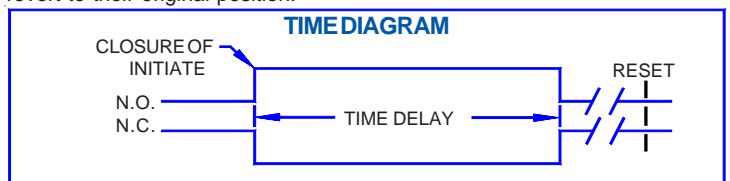

RETRIGGERABLE ONE-SHOT

Power must be applied to the input at all times prior to and during timing. Upon closure of the initiate switch (momentary or maintained) the output contacts transfer and the time delay begins. At the completion of the pre-selected delay period, the output contacts revert to their original position. NOTE: Momentary or maintained closure of initiate switch during timing will reset the time delay.

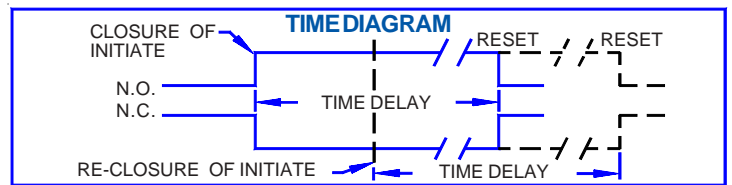

TRAILING EDGE TRIGGERED

Power must be applied to the input at all times prior to and during timing. Upon closure of the initiate switch, nothing happens. When the initiate switch is opened, the time delay begins and the output contact transfers. At the completion of the pre-selected delay period the output contact reverts to its original position. Removal of input power will reset the control. If the initiate switch is closed during timing, the output contact reverts to its original position and the time delay is reset.

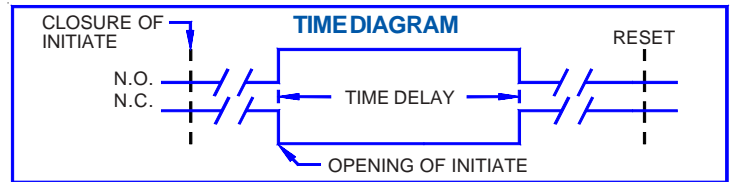

ON/OFF RECYCLE

Upon application of power to the input terminals, the ON delay begins and the output contacts transfer. Upon completion of the ON delay, the output contacts revert back to their original position and the OFF delay begins. Upon completion of the OFF delay, the output contacts again transfer and the cycle repeats. Reset is accomplished by removal of input power.

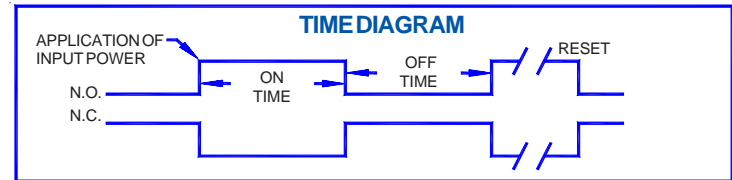

DIMENSIONS

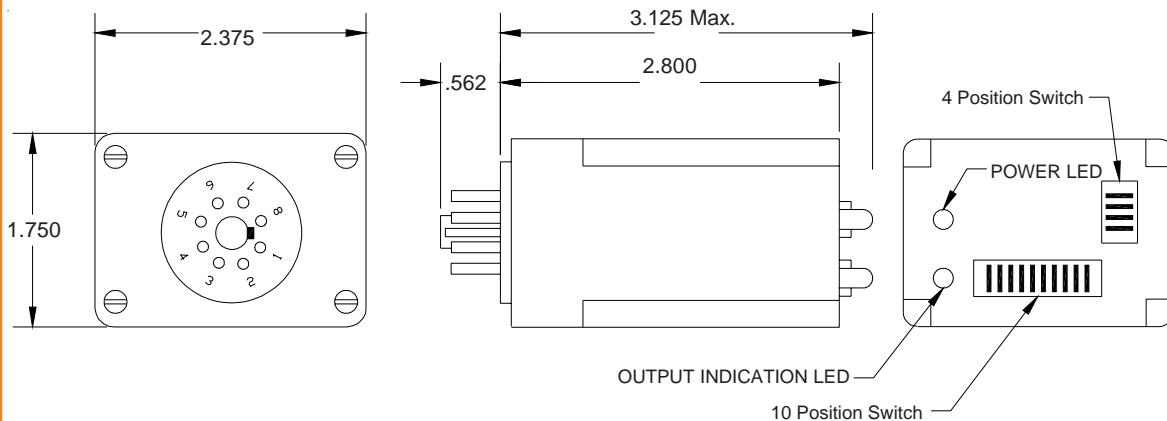

EXAMPLE PROGRAM SETTINGS

- Switch On
- Switch Off

The "PROGRAM SETTINGS" box below shows a unit set for an "INTERVAL" function and 73 seconds of time delay.

CONNECTION DIAGRAMS

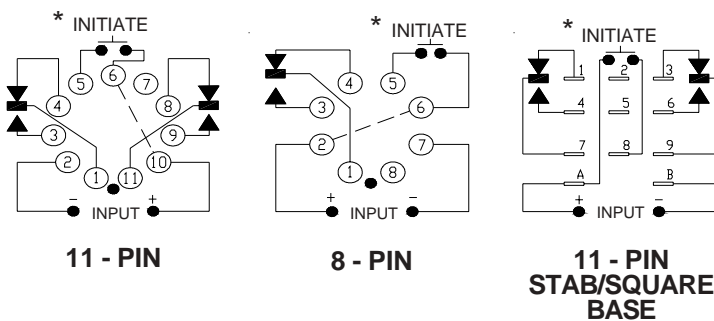

* INITIATE NOT USED FOR INTERVAL, DELAY ON MAKE & RECYCLE MODES OF OPERATION

PROGRAM SETTINGS

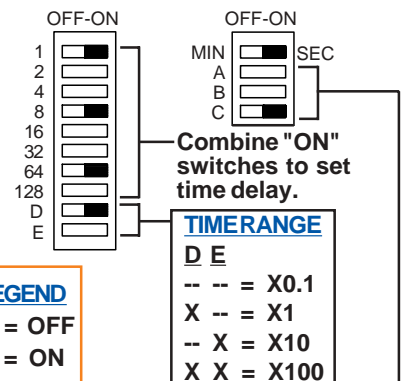

LEGEND
 -- = OFF
 X = ON

TIMERANGE
 D E
 -- -- = X0.1
 X -- = X1
 -- X = X10
 X X = X100

MODES OF OPERATION

- | A | B | C | Mode |
|----|----|----|---------------------------|
| -- | -- | -- | ON/OFF RECYCLE |
| X | -- | -- | SINGLE-SHOT |
| -- | X | -- | DELAY ON MAKE |
| X | X | -- | TRAILING EDGE TRIGGERED |
| -- | -- | X | INTERVAL |
| X | -- | X | RETRIGGERABLE SINGLE-SHOT |
| -- | X | X | DELAY ON BREAK |
| X | X | X | TOGGLE/SINGLE-SHOT |

ORDERING INFORMATION

SERIES	BASE STYLE	INPUT VOLTAGE
DUR	1 - Octal Plug-in (8 Pin)	1 - 12 VDC
	2 - 11 Pin Plug-in	2 - 24/28 VDC
	3 - 11 Pin Stab/Square Base	3 - 110 VDC
		4 - 24 VAC
		5 - 120 VAC
		6 - 230 VAC