



P.O. Box 2956 · Syracuse · New York · 13220
 Phone: (315) 433-1150 Fax: (315) 433-1521
 Toll Free US & Canada (800) 334-0837
 Email: sales@infitec.com

FEATURES

- C/MOS Digital Circuitry
- Time Delays To 1000 Minutes
- No First Cycle Effect
- 0.5% Repeat Accuracy
- Wide Voltage Selection 24-230 VAC, 12-28 VDC
- Medium, High Power or Heavy Duty Output Ratings
- Outputs Available Isolated Or Non-Isolated
- No Heatsinking Required
- Encapsulated To Withstand Harsh Environment
- Seven Modes Of Operation
- UL / cUL Recognized

SPECIFICATIONS

1. Time Delay.

- 1.1 Type: C/MOS digital circuitry
- 1.2 Range: From 0.05 seconds to 1000 minutes. Fixed delays available (see time delay range chart)
- 1.3 Repeat accuracy: $\pm 0.5\%$ under fixed conditions
- 1.4 Setting accuracy: $\pm 10\%$
- 1.5 Reset time: 50 milliseconds maximum
- 1.6 Recycle time: 100 milliseconds
- 1.7 Time delay vs. voltage and temperature: $\pm 5\%$
- 1.8 External Resistance (remote adjust only) : 1 Megohm = maximum delay

2. Input.

- 2.1 Operating voltage: 24, 120 & 230 VAC, 12 & 24/28 VDC
- 2.2 Tolerance: $\pm 20\%$ of nominal
- 2.3 Frequency: 50 - 60 Hertz

3. Output.

- 3.1 Type: Electromechanical relay
- 3.2 Form: SPST, SPDT or DPDT (see ordering information)
- 3.3 Rating: See Output Rating Chart
Note: Available with isolated or non-isolated contacts.
- 3.4 Life: Medium power =
 Electrical - full load - 100,000 operations
 Mechanical - 10,000,000 operations
 High power & Heavy duty =
 Electrical - full load - 100,000 operations
 Mechanical - 10,000,000 operations

4. Protection.

- 4.1 Transient: ± 1500 volts for 150 microseconds
- 4.2 Polarity: DC units are reverse polarity protected
- 4.3 Dielectric breakdown: 1500 volts RMS minimum

5. Mechanical.

- 5.1 Mounting: One #8 or #10 screw
- 5.2 Termination: 1/4" quick connect terminals
- 5.3 Style: Surface mount / encapsulated

6. Environmental.

- 6.1 Operating temperature: -20°C to $+80^{\circ}\text{C}$
- 6.2 Storage temperature: -30°C to $+85^{\circ}\text{C}$
- 6.3 Humidity: 95% relative non-condensing

OUTPUT RATING CHART

	30 VDC	125 VAC	240 VAC
MEDIUM POWER			
N.O.	10A	10A, 1/4hp	10A, 1/4hp
N.C.	5A	5A, 1/4hp	5A, 1/4hp
HIGH POWER			
N.O.	20A	20A, 1hp	20A, 2hp
N.C.	10A	10A, 1/4hp	10A, 1/2hp
HEAVY DUTY			
N.O.	30A	30A, 1hp	30A, 2hp

KKR SERIES MEDIUM/HIGH POWER TIMING CONTROLS



UL
 UL/cUL Recognized

File E125360
 UL Guide NMFT2
 cUL Guide NMFT8

MODE OF OPERATION - SERIES

DELAY ON MAKE - KMKR

Upon application of power to the input terminals, the time delay begins. At the completion of the pre-selected time delay, the output contacts transfer. Reset is accomplished by removal of input power. There is no false output when reset during timing.

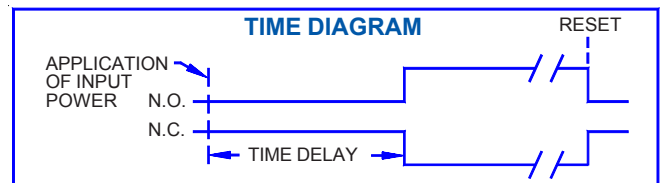

INTERVAL - KIKR

Upon application of power to the input terminals, the output contacts immediately transfer and the time delay begins. At the completion of the pre-selected time delay, the output contacts revert to their original position. Reset is accomplished by removal of input power.

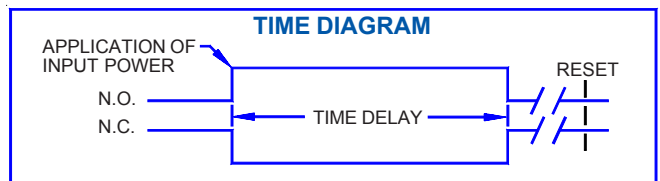

SINGLE SHOT - KSKR

Power must be applied to the input at all times prior to and during timing. Upon closure of the initiate switch (momentary or maintained) the output contacts transfer and the time delay begins. At the completion of the pre-selected time delay, the output contacts revert to their original position. Removal of input power will reset the control. Closure of initiate during timing will have no effect.

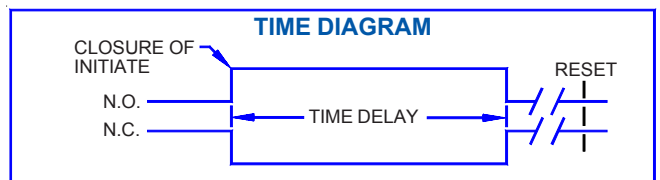

DELAY ON BREAK - KBKR

Power must be applied to the input at all times prior to and during timing. Upon closure of the initiate switch, the output contacts transfer and remain transferred if no further action is taken. When the initiate switch is opened, the time delay begins. At the end of the pre-selected time delay the output contacts revert to their original unenergized position. Removal of input power will reset the control.

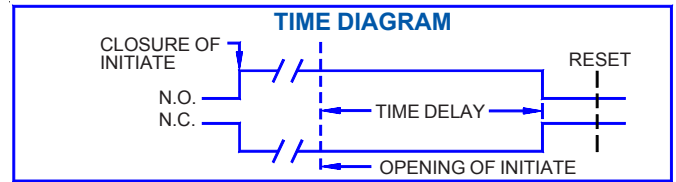

RETRIGGERABLE ONE SHOT - KOKR

Power must be applied to the input at all times prior to and during timing. Upon closure of the initiate switch (momentary or maintained) the output contacts transfer and the time delay begins. At the completion of the pre-selected time delay the output contacts revert to their original position. **NOTE:** Momentary or maintained closure of initiate switch during timing will reset the time delay.

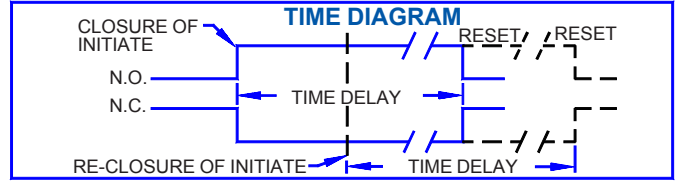

TRAILING EDGE TRIGGERED - KTKR

Power must be applied to the input at all times prior to and during timing. Upon closure of the initiate switch, nothing happens. When the initiate switch is opened, the time delay begins and the output contact transfers. At the completion of the pre-selected delay period the contact reverts to its original position. Removal of input power will reset the control. If the initiate switch is closed during timing, the output contact reverts to its original position and the time delay is reset.

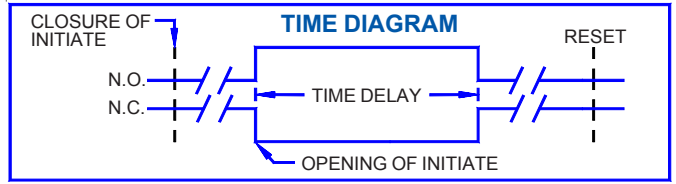

ON/OFF RECYCLE - KRKR

Upon application of power to the input terminals, the **ON** delay begins and the output contacts transfer. Upon completion of the **ON** delay, the output contacts revert back to their original position and the **OFF** delay begins. Upon completion of the **OFF** delay, the output contacts again transfer and the cycle repeats. Reset is accomplished by removal of input power. **Note:** 1st & 2nd delays are equal

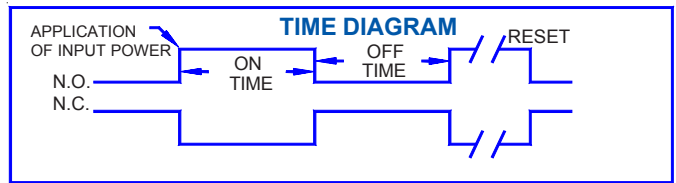

OFF/ON RECYCLE - KRKR

Opposite of ON/OFF RECYCLE **Note:** 1st & 2nd delays are equal

DIMENSIONS

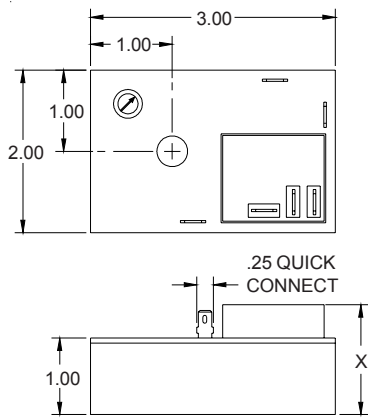

X = 1.75 MAX. FOR OUTPUT RATING "T"
X = 1.5 MAX. FOR OUTPUT RATING "A,B,E,F"

CONNECTION DIAGRAMS

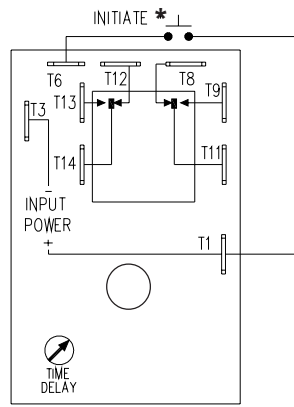

OUTPUT RATING "T"
(LOCAL ADJ. SHOWN)

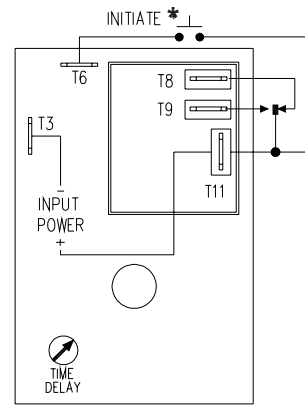

OUTPUT RATING "E" & "F"
(LOCAL ADJ. SHOWN)

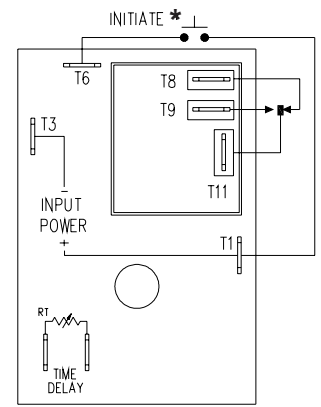

OUTPUT RATING "A" & "B"
(EXTERNAL ADJ. SHOWN)

*INITIATE SWITCH FOR MODELS KBKR, KOKR, KSKR & KTKR ONLY.

ORDERING INFORMATION

SERIES	INPUT VOLTAGE	OUTPUT RATING	ADJUSTMENT	TIME DELAY RANGE				
KBKR KIKR KMKR KOKR KSKR KTKR	1 - 12 VDC 2 - 24/28 VDC 4 - 24 VAC 5 - 120 VAC 6 - 230 VAC	A - Medium Power SPDT Isolated B - High Power SPDT Isolated C - Heavy Duty SPST Isolated E - Medium Power SPDT Non-Isolated F - High Power SPDT Non-Isolated G - Heavy Duty SPST Non-Isolated T - Medium Power DPDT Isolated	0 - Local 1 - Fixed 2 - Remote Adjustment	See Time Delay Range Chart				
KRKR				<table border="1"> <tr> <td>KRKR ONLY</td> <td>TIME DELAY</td> </tr> <tr> <td>1 - On Time First 2 - Off Time First</td> <td>See Time Delay Range Chart NOTE: 1st & 2nd delays are equal</td> </tr> </table>	KRKR ONLY	TIME DELAY	1 - On Time First 2 - Off Time First	See Time Delay Range Chart NOTE: 1st & 2nd delays are equal
KRKR ONLY	TIME DELAY							
1 - On Time First 2 - Off Time First	See Time Delay Range Chart NOTE: 1st & 2nd delays are equal							